

Präzisionswerkzeuge

Made in Germany

Reihe 400

MITLAUFENDE PRÄZISIONS-ZENTRIERKEGEL
BULL NOSE LIVE CENTER

Conzella[®]

PRÄZISIONSWERKZEUGE

Conzella Präzisionswerkzeuge GmbH
Auf Lichtenbol 1 | 72461 Albstadt
Fon +49 7432.5326

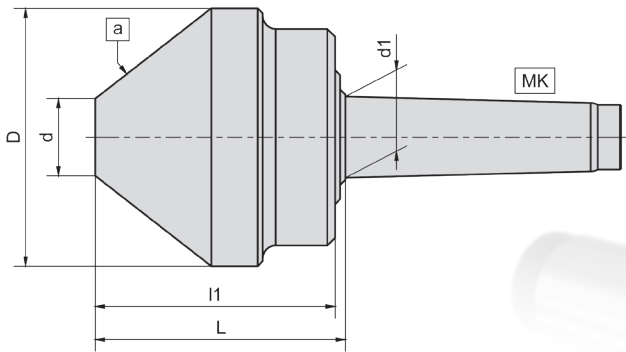

Type	MK	D	d	d1	L	l1	a	Drehzahl max. [1/min]	Werkstück gewicht max. an d [kg]	Werkstück gewicht max. an D [kg]	Rundlauf-Abweichung max. [mm]	Axialdruck max. [kN]
Type	MT	D	d	d1	L	l1	a	Rotational frequency max. [1/min]	Workpiece weight max. an d [kg]	Workpiece weight at D [kg]	Concentricity run-out max. [mm]	Thrust load max. [kN]
421	2	60	20	17,78	73	66	60°	4000	140	200	0,005	1,85
431	3	80	30	23,83	86	78	60°	3500	250	450	0,005	3,30
432	3	100	30	23,83	100	92	75°	3000	250	400	0,005	4,85
441	4	100	30	31,27	101	92	75°	3000	300	650	0,005	4,85
442	4	125	50	31,27	91	82	75°	3000	500	650	0,007	4,85
451	5	125	50	44,40	92	82	75°	3000	1400	1800	0,007	4,85
452	5	150	50	44,40	112	102	75°	2800	1200	1900	0,007	9,56
453	5	200	50	44,40	136	126	75°	1800	1000	2000	0,010	15,20
461	6	150	50	63,35	112	102	75°	2800	2000	2800	0,010	9,56
462	6	200	50	63,35	136	126	75°	1800	1800	2800	0,010	15,20

Produkteigenschaften

- Zur Bearbeitung von Rohren und Hohlkörpern mit großen Bohrungen oder Zentren
- Komplettes Werkzeug gehärtet und geschliffen
- Wartungsfreie Dauerschmierung

Product features

- For machining tubes and hollow parts with large-diameter holes or centers
- Complete tool hardened and ground
- Maintenance-free permanent lubrication